

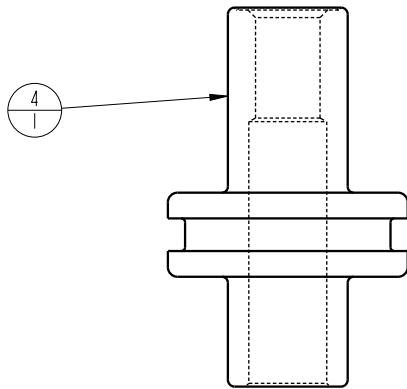

THIS IS A TWO PAGE PARTS LIST.  
 THIS SECOND PAGE APPLIES TO  
 MODEL No. 42021000 AT REVISION H AND EARLIER REVISIONS

Lubricate seals with clean hydraulic oil prior to assembly.  
 DO NOT USE SILICONE BASED LUBRICANTS

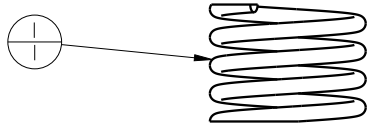
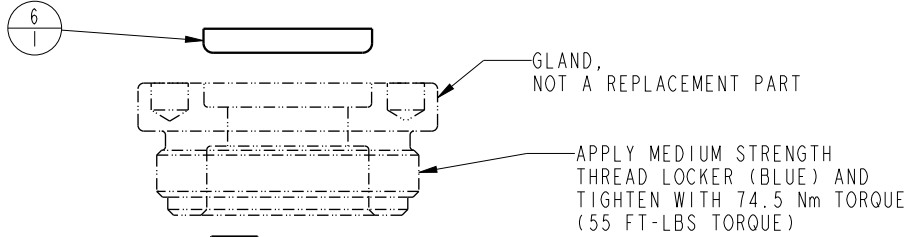

No.	QTY	PART No.	DESCRIPTION	Std. Seal Kit	FKM Seal Kit	Spring Kit	NOTED
N/A	N/A	46100030	SPRING KIT				NOTED
N/A	N/A	6V202113	SEAL KIT, FKM				NOTED
N/A	N/A	46000039	SEAL KIT, STANDARD				NOTED
6	1	39V11020	WIPER, PRESS-IN, (5/8)	X	X		
5	1	49001904	BREATHER, 1/8 BSPP				
4	1	48011300	PISTON, CYL, HR, 20.6 KN				
3	1	39052036	SEAL, LL, (5/8 X 1/8 X 1/8 X 7/8)	X		39052002	
2	1	39011027	SEAL, BEVEL, 1-1/16 x 3/32 x 1-1/4	X		39052012	
1	1	23314005	SPRING, COMPRESSION				X

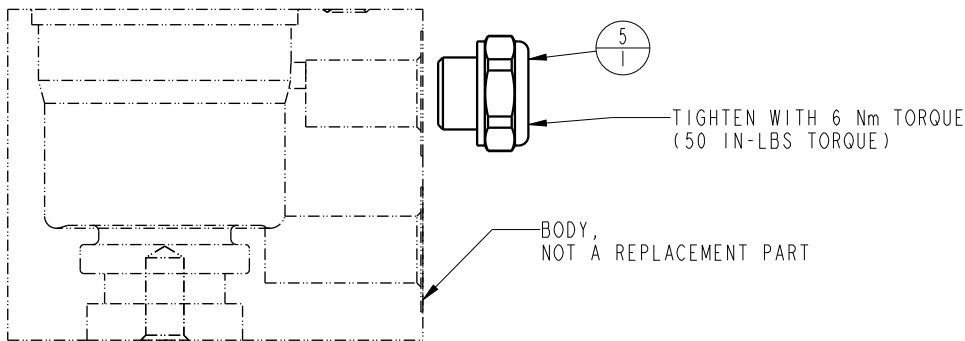
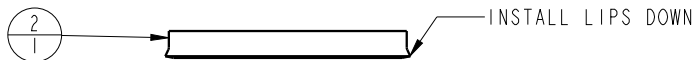

**PARTS LIST**



VEKTEK, INC.  
 1334 E. SIXTH AVE. P.O. BOX 625  
 EMPORIA, KS. 66801 U.S.A.

ASSEMBLIES AFFECTED  
 42021000

PARTS LIST, ASSY, CYL, HR, 20.6 KN, SA

L	5486	RELEASE	JDW	08/16/24
REV	IN ACCORDANCE WITH ECN	EFFECTIVE DATE	REVISED BY	DATE
DRW BY:	BUSH	DRAWING STATUS: <b>Released</b>		
DATE:	12/14/94	PRODUCTION APPROVED FOR RELEASED STATUS ONLY		

SIZE  
A MPL2029 REV  
1

FORM FEG035\_PL\_ASIZE, REV. B

SHEET 2 OF 2